

Gas-Fired Tempered Make-Up Air Unit / DX

Model:

TK3-DX-3PH-FF

3-Phase, 230V, 7.50 HP, Belt driven with Motorized Damper and 18" Blower. MAX 7000 CFM's

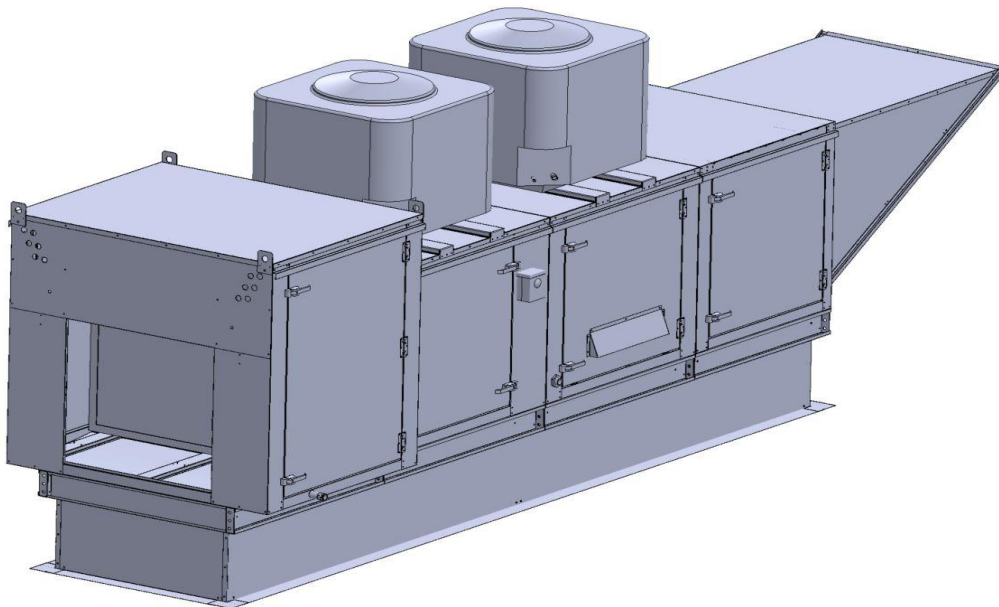



TK3-750 Direct Fired MPU (2521 lbs./142 curb)

Supply Motor:

Model DTP7/54, 7.500 HP, 3 Phase, 230 V, 60Hz, 19.1 FLA, ODP, Premium (E-Plus3) Eff.

Supply Motor Pulleys:

<u>Part Type</u>	<u>Qty</u>	<u>Browning #</u>	<u>Turns Out</u>
Belt	2	BX69	
Blower Pulley	1	2BK120H	
Bushing	1	H-1 3/16	
Motor Pulley	1	2VP75X1-3/8	2.5

Burner:

Min Output BTU: 27,500 BTU/Hr
Max Output BTU: 825,000 BTU/Hr
Size: 18" long
Gas Type: Natural

Supply Performance:

Volume: 7000 cfm Volume Range: 5400-7000 cfm
RPM: 1031
TS: 4858 ft/min
SP: 1.580" w.g.
0.500" Ext. + 0.138" Int. + 0.942" Opt.
BHP: 5.773

Heating Schedule:

Altitude: 0'
Winter Entering Air Dry Bulb Temp: 0°F
Temp Rise: 100°F
Output BTU: 756000
Input BTU: 821739
BTUs BASED OFF STANDARD AIR DENSITY

Cooling Schedule:

DX Coil Entering Dry Bulb Temperature: 90°F
DX Coil Entering Wet Bulb Temperature: 72°F
DX Coil Leaving Dry Bulb Temperature: 74°F
DX Coil Leaving Wet Bulb Temperature: 66°F
DX Coil Total Capacity: 161.4 MBH
DX Coil Sensible Capacity: 120.5 MBH
DX Coil Latent Capacity: 40.9 MBH
Temperature drop calculations are based on tested data.

Supply Installation Information:

Gas Inlet Pressure: 7 in. w.c. - 14 in. w.c.
Insurance: No Insurance Requirement (ANSI)
Unit Main Input: 25.0 Amps MCA, 40 Amps MOP, 230 V, 10 AWG Wire Min.
Condenser #1: 21.4 Amps MCA, 30 Amps MOP, 208-230, 12 AWG Wire Min.
Condenser #2: 21.4 Amps MCA, 30 Amps MOP, 208-230, 12 AWG Wire Min.
Condenser #3: 21.4 Amps MCA, 30 Amps MOP, 208-230, 12 AWG Wire Min.

Construction Features

Housing constructed of heavy duty G90 galvanized steel • Forward curved centrifugal blower wheel • Vibration isolation • Adjustable drive assemblies • Adjustable motor mount • Ball bearing motors • Heavy duty, pre-lubricated bearings rated for 200,000 hours of operation • Static resistant belts • Service doors on both sides • Horizontal & down discharge • Large intake area ensures low pressure drop across unit • Spring loaded profile plates automatically adjust for any airflow - no manual setting required! • Weatherproof safety disconnect switch • Modular design provides design flexibility • Fully insulated casing

Blower:

18" forward curved, centrifugal blower. Pillow Block ball bearings. Galvanized finish. 4000-12000 CFM. 1-3/16" x 34" Shaft. 1450 max. RPM. Used in heated and non-heated supply fans.

Temp Control:

RTC Solutions • 40-90°F Discharge Temp Control • Field Wired On/Off Start Command

Intake:

Sloped Filtered Intake for Size #3 Modular Heater. 37.25" Wide X 51.625" Long X 35.188" High. Includes 2" MV EZ Kleen Metal Mesh Filter.

Filters:

6x MV EZ Kleen Metal Mesh Filter. 16"x 20"x 2" Used for heater and supply fan intakes. (3412)

Curb & Supports:

RAIL - 6" Width X 35" Length X 20" Height
RAIL - 6" Width X 35" Length X 20" Height
ROOF CURB - 35" Width X 84" Length X 20" Supply Height, Insulated

Selected Options:

- Motorized Back Draft Damper 30" X 30" for Size 3 Standard & Modular Heater Units w/Extended Shaft, Standard Galvanized Construction, 3/4" Rear Flange, Low Leakage, NFBUP-S Actuator Included
- Low Fire Start. Allows the burner circuit to energize when the modulation control is in a low fire position.
- Gas Pressure Gauge, 0-35", 2.5" Diameter, 1/4" Thread Size
- Gas Pressure Gauge, -5 to +15 Inches Wc., 2.5" Diameter, 1/4" Thread Size
- 15 Ton, 3 Circuit (5/5/5) Modular Packaged Cooling Option for Size 3 Modular Packaged Unit. Includes Condenser, DX Coil, Filter/Dryer Kit, Hard Start Kit, Thermal Expansion Valve, R410A Refrigerant, and Refrigerant Piping. (5,400 to 7,000 cfm) NOT BUILT WITH OPPOSITE SIDE CONTROLS OR OPPOSITE AIRFLOW DIRECTION. CONDENSERS REQUIRE SEPARATE 208V, 3 PHASE POWER SUPPLY UNLESS ORDERED WITH SINGLE POINT CONNECTION. Coil = 3EZ1002B
- Downturn Plenum for Size 3 Cooling Coil Module - Required for Down Discharge Cooling Coil Applications

Supply Unit Voltage: 3 phs 230 V 60Hz

- DX Cooling Intake Air Thermostat and Relays Mounted in Unit - Set Point For Thermostat Should Be 85°F.
- Support shell for Size 3 Modular Package Unit for Third Condenser. Includes control vestibule. Includes condenser supports. Does not include return air or inlet air damper.

- TK3 DIRECT FIRED HEATER WITH DX COOLING
1. DIRECT GAS FIRED HEATED MAKE UP AIR UNIT WITH 18" BLOWER AND 12" BURNER.
 2. INTAKE HOOD WITH EZ FILTERS
 3. DOWN DISCHARGE - AIR FLOW RIGHT → LEFT
 4. MOTORIZED BACK DRAFT DAMPER 30" X 30" FOR SIZE 3 STANDARD & MODULAR HEATER UNITS W/EXTENDED SHAFT. STANDARD GALVANIZED CONSTRUCTION, 3/4" REAR FLANGE, LOW LEAKAGE, NFBUP-S ACTUATOR INCLUDED
 5. LOW FIRE START: ALLOWS THE BURNER CIRCUIT TO ENERGIZE WHEN THE MODULATION CONTROL IS IN A LOW FIRE POSITION.
 6. GAS PRESSURE GAUGE, 0-35", 2.5" DIAMETER, 1/4" THREAD SIZE
 7. GAS PRESSURE GAUGE, -5 TO +15 INCHES WC., 2.5" DIAMETER, 1/4" THREAD SIZE
 8. 15 TON, DUAL CIRCUIT (10/5) MODULAR PACKAGED COOLING OPTION FOR SIZE 3 MODULAR PACKAGED UNIT. INCLUDES CONDENSER, DX COIL, FILTER/DRYER KIT, THERMAL EXPANSION VALVE, R410A REFRIGERANT, AND REFRIGERANT PIPING.
 9. FULL CRATING FOR COMMERCIAL HEATERS FOR SHIPPING.
 10. DOWNTURN PLENUM FOR SIZE 3 COOLING COIL MODULE - REQUIRED FOR DOWN DISCHARGE COOLING COIL APPLICATIONS
 11. DX COOLING INTAKE AIR THERMOSTAT AND RELAYS MOUNTED IN UNIT - SET POINT FOR THERMOSTAT SHOULD BE 85°F.

NOTE: SUPPLY DUCT MUST BE INSTALLED TO MEET SMACNA STANDARDS. A MINIMUM STRAIGHT DUCT LENGTH MUST BE MAINTAINED DOWNSTREAM OF UNIT DISCHARGE UNLESS OTHERWISE SPECIFIED. DO NOT RELY ON UNIT TO SUPPORT DUCT IN ANY WAY. FAILURE TO PROPERLY SIZE DUCTWORK MAY CAUSE SYSTEM EFFECTS AND REDUCE PERFORMANCE OF THE EQUIPMENT.

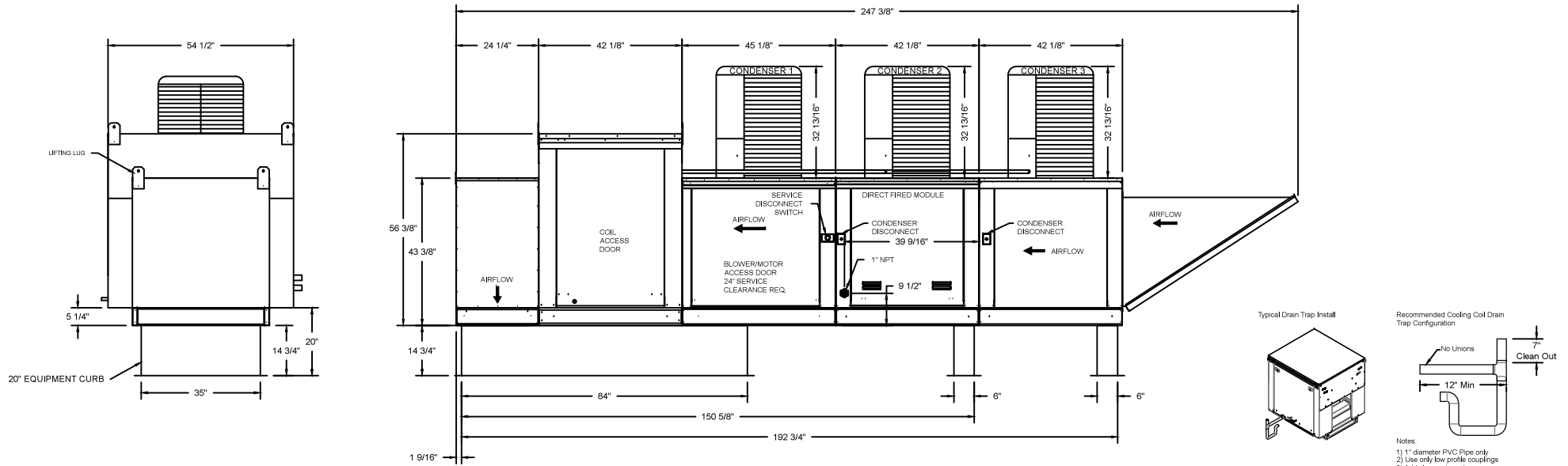
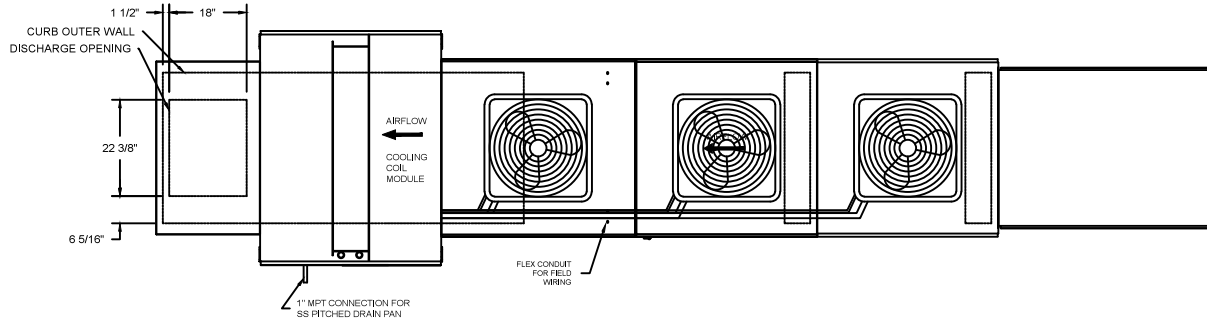

- Notes:
- 1) 1" diameter PVC Pipe only
 - 2) Use only low profile couplings
 - 3) Add clean out as shown

	NORTH AMERICAN KITCHEN SOLUTIONS INCORPORATED	JOB	
		LOCATION	
		DATE 8/31/18	JOB #
		DWG #	DRAWN BY
		REV.	SCALE

(MPU 7000 7.5HP/3PH-230V) - HEATER PERFORMANCE CURVES.

7000 CFM, 1.58 SP @ 1031 RPM and 5.773 BHP at 0 feet and 100 deg F

* Please note that these curves were adjusted for job specific temperature and altitude.

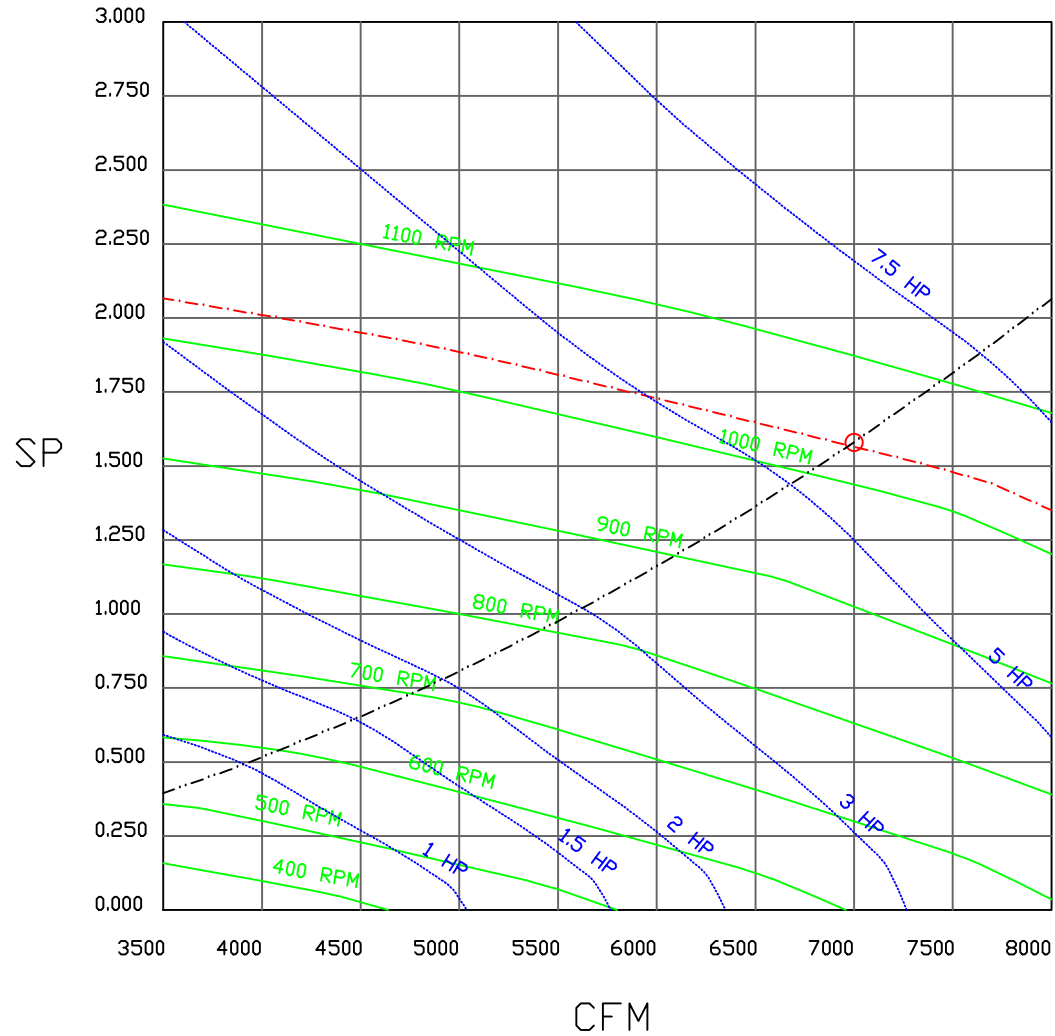

			JOB	
			LOCATION	
			DATE 8/27/2018	JOB #
			DWG #	DRAWN BY
			REV.	SCALE 3/8" = 1'-0"

Modular Package Unit Wiring

JOB NAKS DIRECT FIRED MPU

DRAWING NUMBER

SHIP DATE

MODEL TK 1-4 Series

ATTENTION ELECTRICIAN!
 DROP FOR DISCONNECT CONNECTION
 IS FACTORY SUPPLIED
 CONNECT POWER TO THE DROP

Installed Options
 Field Wired Single Switch Control
 Motorized Back Draft Damper

Discharge Temp. Control
 Cooling Thermostat and Relay

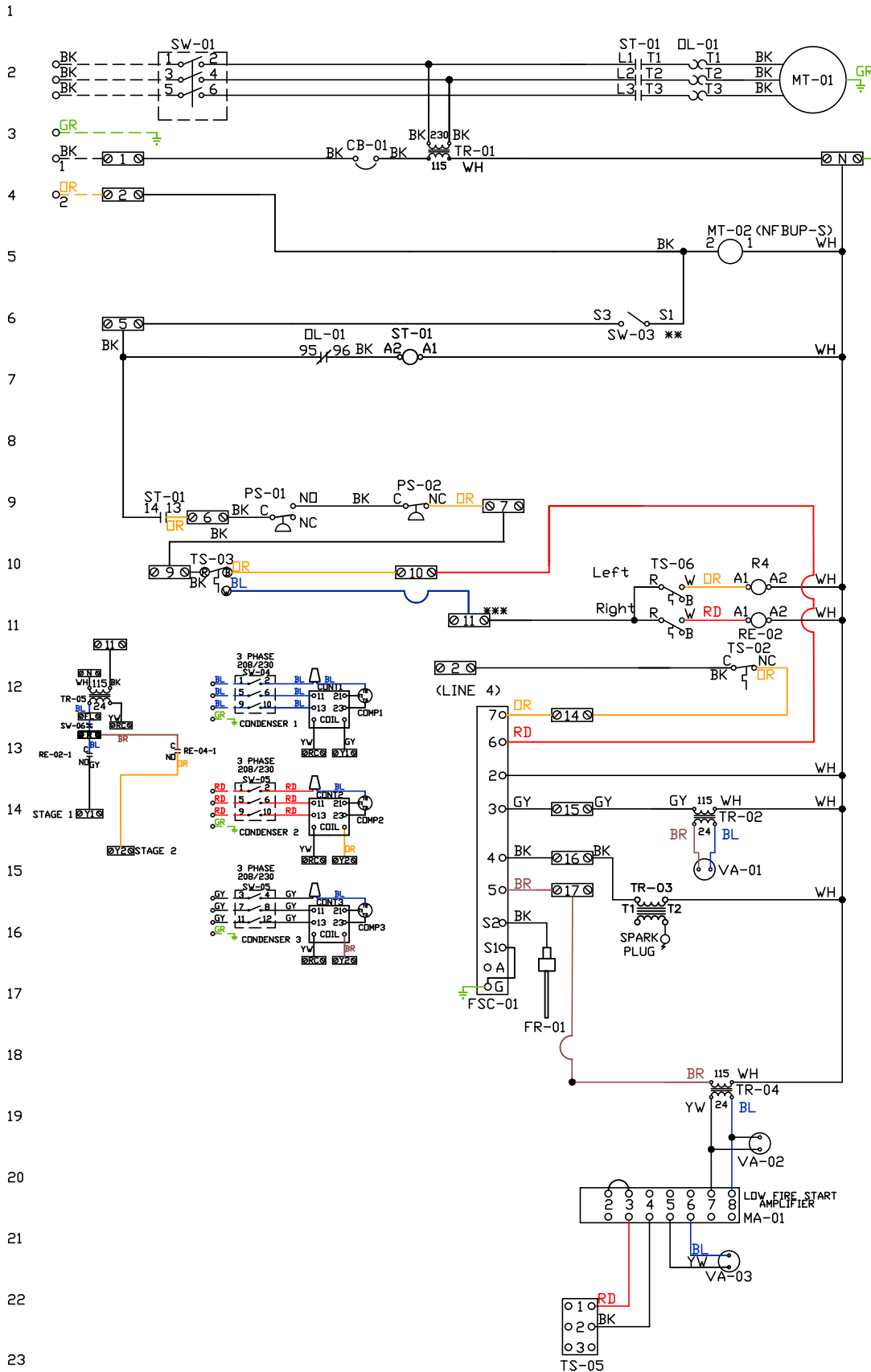

Label	Component Identification Description	Location
CB-01	Circuit breaker (2amp)	[3]
FR-01	Flame rod	[16]
FSC-01	Fireye FSC	[11-14]
MA-01	Modulating amplifier	[19]
MT-01	Supply motor	[2]
MT-02	Damper motor	[5]
DL-01	Supply motor overload	[2][7]
PS-01	Low Airflow Switch	[9]
PS-02	High Airflow Switch	[9]
RE-02	Stage 1 Heat/Cool Relay	[11][13]
RE-04	Stage 2 Cooling Relay	[11][13]
ST-01	Supply motor contactor	[2][7][9]
SW-01	Main disconnect switch	[2]
SW-03	Damper end limit switch	[4]
SW-04	40 Amp Rotary Disconnect	[12-14]
SW-05	40 Amp Rotary Disconnect	[14-15]
SW-06	Overflow Switch	[12-13]
TR-01	Power transformer(200v/53)	[1]
TR-02	Power transformer(20v)	[12]
TR-03	Ignition transformer	[14]
TR-04	Power transformer(20v)	[17]
TR-05	Cond Transformer(40v)	[12]
TS-02	High temp limit switch	[10]
TS-03	Intake Air Sensor	[10]
TS-05	Discharge Air Sensor	[21]
TS-06	Cooling Thermostat	[16]
VA-01	Pilot gas valve	[13]
VA-02	Main gas valve	[18]
VA-03	Modulating gas valve	[20]

SUPPLY	MOTOR INFO
7.5HP-230V-3P-19.1FLA	
CONTACTOR: 100-C23D10	
OVERLOAD: 193-T1AC20	

ELECTRICAL INFORMATION
 MOTOR/CTRL CIRCUIT MCA: 25.0A
 MOTOR/CTRL CIRCUIT MOP: 40A
 COND1 MCA = 21.4A COND1 MOP = 30A
 COND2 MCA = 21.4A COND2 MOP = 30A
 COND3 MCA = 21.4A COND3 MOP = 30A

NOTES
 --- DENOTES FIELD WIRING
 ——— DENOTES INTERNAL WIRING

** TERMINALS S4 AND S6 USED ON NF & AF SERIES ACTUATORS
 *** TERMINAL 11 PROVIDES COOLING CONNECTION

WIRE COLOR	SOCKET STYLE
BK-BLACK	ND 4 3
BL-BLUE	NC 2 1
BR - BROWN	COIL 8 7
DR - ORANGE	COM 6 5
GY - GRAY	
GR - GREEN	
WH - WHITE	
PR - PURPLE	
RD - RED	
PK - PINK	
YW - YELLOW	

Installation Wiring

JOB NAKS Direct Fired MPU

DRAWING NUMBER

SHIP DATE

MODEL TK 1-4 Series

Installed Options

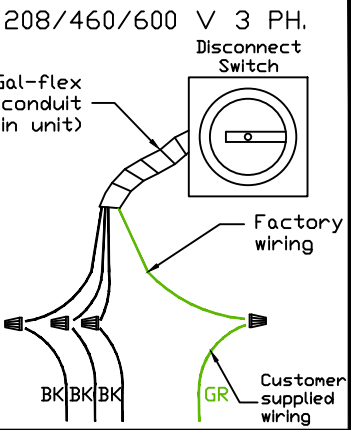
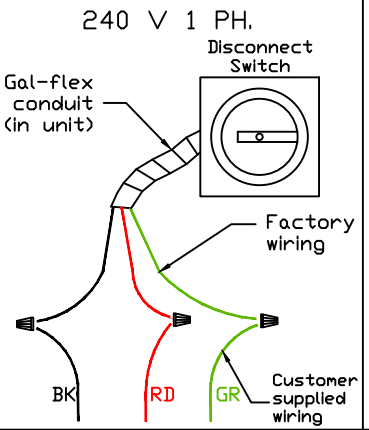
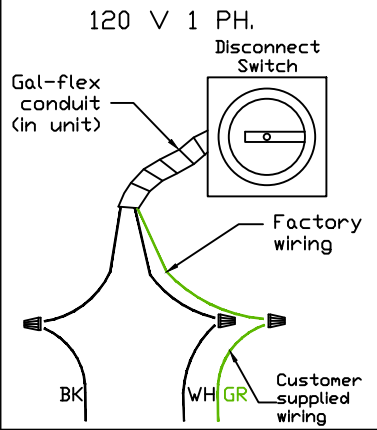

Field Wired On/Off Switch

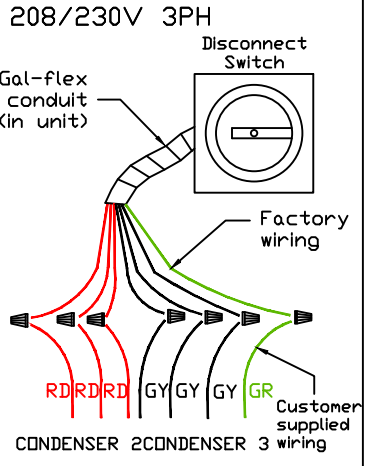
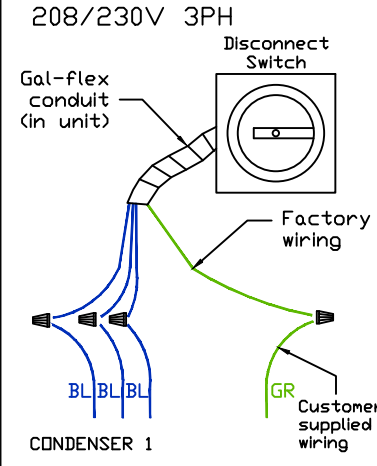

DO NOT CONNECT CONDENSER POWER DROPS TO KITCHEN CONTROL PACKAGE STARTERS OR VFDS

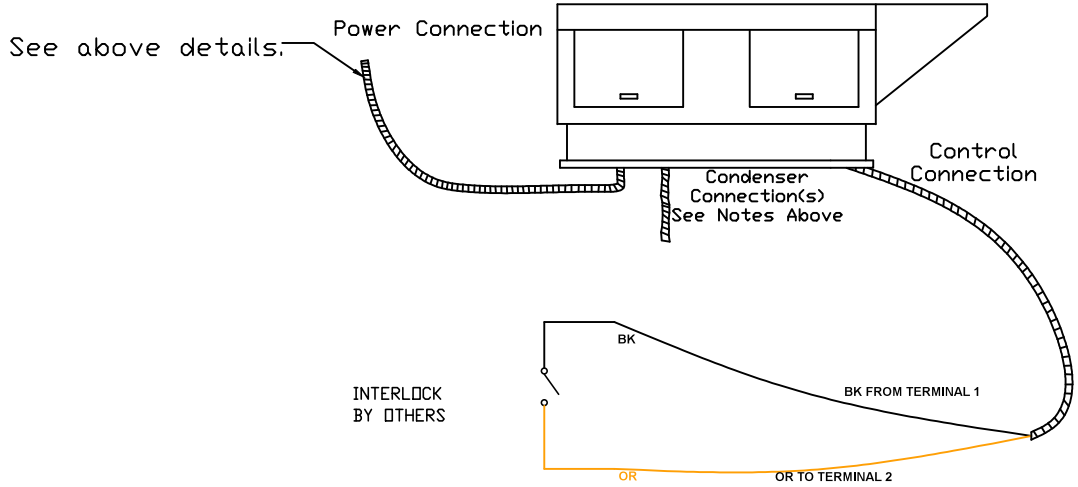

NOTES

WIRE COLOR

- | | |
|-------------|-------------|
| BK - BLACK | YW - YELLOW |
| BL - BLUE | GR - GREEN |
| BR - BROWN | GY - GRAY |
| OR - ORANGE | PR - PURPLE |
| RD - RED | PK - PINK |
| WH - WHITE | |